

## SPG 422 Component Digital Master Sync Generator



SPG 422 Component Digital Master Sync Generator.

The SPG 422 is a master sync generator designed to meet the transitional and long term needs of the serial component digital post production and operational environments. While component digital is gaining momentum, many facilities will still be largely analog with digital islands and virtually all will output materials in analog form. The SPG 422 provides the basic timing and test signals needed to operate these mixed format environments.

### Single or dual standard operation

The SPG 422 provides front panel selection of single or dual standard operation. In the single standard mode, the black burst outputs follow the line and field rate selection for the digital outputs, i.e., NTSC for 525/60 operation and PAL for 625/50 operation. In the dual standard mode, each serial digital

video and analog black output is individually configurable.

In the dual standard mode, the SPG 422 is ideally suited for use as the house master providing simultaneous NTSC and PAL black burst outputs and a clock locked AES/EBU digital audio output. The SPG 422 is also the perfect companion for dual standard telecines in film to tape transfer operations.

### Analog black burst outputs

The base SPG 422 provides two independently timeable PAL or NTSC outputs with over two fields of advance and delay range. In this configuration, the SPG 422 is ideally suited for use as a slave sync generator in a serial digital island or as a system master in a small serial digital facility. Sub-nanosecond timing adjustment resolution facilitates

### FEATURES AND BENEFITS

Conforms to ITU-R BT.601/656; EBU N14, Tech. 3267; SMPTE 259M, 272M, 276M, RP 154, RP 155, RP 165; ANSI S4.40 (AES 3)

525/60, 625/50, or Dual Standard Operation

Multiple, Independently Timeable Analog Black Burst Outputs

High Stability Internal Reference With Genlock to NTSC or PAL

CW Lock to NTSC and PAL  $F_{SC}$  and 1, 5, and 10 MHz

Full Time Serial Digital Color Bars and Black Outputs

Character ID Displays one of Four Text Strings on the Serial Digital Color Bars Signal

AES/EBU Serial Digital Audio Outputs (XLR and BNC)

Audio Click May be Added to Right AES/EBU Audio Channels

Optional Serial Digital Video Test Signal Output

User Presets with Non-volatile Storage

RS-232 or Ground Closure Remote Control

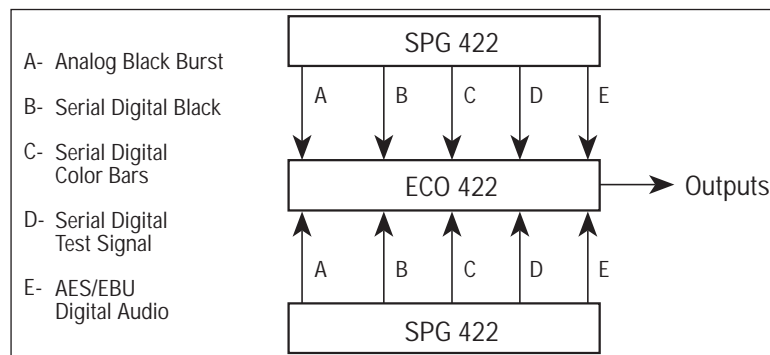

Component digital master sync system. The ECO 422 provides eleven user configurable signal channels, each consisting of primary and backup inputs and an output.

timing of the digital island's analog output into the house analog system.

For larger, more complex systems, the SPG 422 may be fitted with four additional independently timeable black burst outputs that differ only in adjustment resolution (clock cycle vs. sub-nanosecond) from those provided in the base unit. These outputs are intended for use as a timing reference for equipment with serial digital video outputs connected into a destination with auto timed inputs, e.g., a digital production switcher. As in the base unit configuration, the SPG 422 is well suited for either house master or slave applications.

#### High stability internal reference and genlock

The SPG 422 has a high accuracy 13.5 MHz internal reference with less than 1 ppm per year long term drift. This level of performance makes the SPG 422 suitable for use as a master SPG for virtually all applications. The genlock is a burst lock implementation that provides the low jitter performance required when the SPG is the timing reference for digital in/analog out devices such as encoders, synchronizers, and the like.

#### Serial digital outputs

The SPG 422 provides one output each of serial digital black and serial digital color bars. In the 525/60 mode, SMPTE color bars or 100% full field color bars are available. In the 625/50 mode, 100% color bars over red and full field color bars are provided. One of four user programmable text strings of up to ten characters may be selected for display in the serial digital color bars signal. All color bar selections are made from the front panel. Four channels of AES/EBU digital audio with front panel control of level and frequency are provided on BNC and XLR connector outputs. A click may be added to the right audio channels of the AES/EBU audio outputs to identify them from the left channels. The click is on the separate AES/EBU outputs only. If desired, the user may embed digital audio in the serial digital color bars and black signals. Separate selection of silence or tone is provided on the serial digital black output. The serial digital color bars and black and AES/EBU digital audio outputs provide the signals needed for tape preparation and for general plant routing.

A serial digital test signal generator, with test signals chosen to facilitate operations and first line maintenance, is available as an option. The test signal complement includes color bars, full field pluge, crosshatch, bowtie, active picture markers, multiburst, pulse and bar, ramp, and the SDI check field signals. Test signals may be selected from the front panel or via RS-232 remote control. Two BNC outputs are provided.

#### User presets with nonvolatile storage

The SPG 422 has nonvolatile storage for four complete instrument setups (presets). This provides a quick and easy means for saving and recalling timing, test signal, and audio setups in applications where the SPG 422 outputs are delegated to more than one piece of equipment. Presets may be recalled from the front panel or via remote control.

#### Full remote control

RS-232 or ground closure remote control are provided on the SPG 422. All front panel controls are duplicated under RS-232 control. Ground closure control provides access to major instrument functions such as internal or external reference select, test signal select, and recall of user presets.

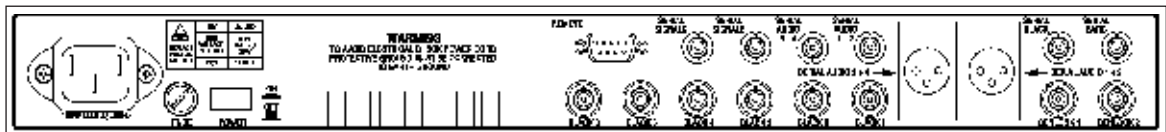

SPG 422 rear panel.

## SPG 422 Characteristics

### SERIAL DIGITAL VIDEO OUTPUTS

**Standards Conformance** – ITU-R BT 601/656 (CCIR 601/656); EBU Tech. 3267; SMPTE 259M, 272M, RP155, RP165.

**Reference and Test Signals** – Color Bars: SMPTE, 75% and 100% full field; 75% and 100% color bars over red. Black Test Signals (option): Color bars as above, pluge, convergence, bowtie, active picture

**Coding** – 10-Bit linear PCM, all channels.

**Quantization to Video Level Relationships** – Y: 877 levels corresponding to video levels 64 through 940. C<sub>B</sub>, C<sub>R</sub>: 897 levels centered around level 512.

**Ancillary Data** – EDH (RP165); embedded audio, 20 bits, same channels, frequencies, and levels as AES/EBU Digital Audio Outputs.

**Format/Bit Rate** – Scrambled NRZI @ 270 Mbs/sec.

**Amplitude** – 800 mV ±10%.

**Rise and Fall Times** – <1.5 ns.

**Jitter** – <0.25 ns, averaged over a period of one horizontal line.

**Output Impedance** – 75 Ω.

**Return Loss** – >15 dB, 5 to 270 MHz.

### SERIAL DIGITAL AUDIO OUTPUTS

**Standards Conformance** – ANSI S4.40 (AES 3); SMPTE 276M.

**Number of Audio Channels** – 4; 2 AES/EBU audio pairs.

**Audio Tones** – Frequency: 1 kHz, 800 Hz, silence. Level: -10 to -20 dBFS in 2 dB steps.

**Pre-emphasis** – None.

**Sampling Frequency** – 48.000 kHz, locked to video.

**Coding** – Linear PCM, 20 or 24 bits, twos complement binary representation, bi-phase mark coding.

**Amplitude** – Unbalanced (BNC): 1 V ±0.2 V. Balanced (XLR): 3 to 10 V<sub>p-p</sub>.

### INTERNAL REFERENCE

**Frequency** – 13.5 MHz.  
**Stability** – <1 ppm per year long term drift.

### ANALOG BLACK BURST OUTPUTS

**Standards Conformance** – SMPTE RP 154 (NTSC); EBU N14 (PAL).

**F<sub>sc</sub> Stability** – ±1 Hz over temperature.

**NTSC Parameters** – Blanking Width: 10.7 μs ±0.2 μs. Setup Level: 0 or 7.5 IRE, user selectable.

**SCH Phase** – 0 degrees ±5 degrees.

**Return Loss** – >30 dB to 5 MHz.

### GENLOCK

**Input Configuration** – One 75 Ω loop through or two 75 Ω terminating inputs, user selectable.

**Return Loss** – >36 dB to 5 MHz.

**Input Requirements** – Signals: NTSC or PAL black burst. Amplitude: Nominal ±3 dB. S/N Ratio: >40 dB. SCH Phase: Nominal ±40 degrees. Signals: 1, 3.58, 4.43, 5, and 10 MHz CW. Amplitude: 2 V<sub>p-p</sub>.

**Performance** – Pull-in Range: F<sub>sc</sub> ±20 Hz. Jitter: Burst Lock: <0.5 degrees. Sync Lock: <2 ns.

### OUTPUT TIMING RANGES

**Genlock** – Range: ±2 fields, ±8.5 lines; moves all timing relative to the reference input. Resolution: <0.5 degrees of subcarrier.

**Black Burst Outputs** – Range: ±2 fields, ±8.5 lines, relative to the genlock timing setting.

**Resolution** – Outputs 1 and 2: Field: field increments. Vertical: Line increments. Horizontal: <0.5 degrees of subcarrier. Outputs 3 Through 6: Field: field increments. Vertical: Line increments. Horizontal: 74 ns (one clock cycle).

**Digital Video Outputs** – Range: ±1 field, ±8.5 lines, relative to the genlock timing setting. Resolution: Field: Field increments. Vertical: Line increments. Horizontal: 74 ns (one clock cycle).

### POWER SOURCE

**Mains Ranges** – Voltage: 90 to 132, 180 to 250 V AC. Frequency: 48 to 62 Hz.

**Power Consumption** – 60 W maximum.

### ENVIRONMENTAL

**Temperature** – Operating: 0°C to 50°C. non-operating: -40°C to 65°C.

### CERTIFICATIONS

**EMC** – Certified to the EMC Directive 89/336/EEC.

**Safety** – Approved to: UL3111-1, CAN/CSA-C22.2 No.1010.1. Complies with: EN61010-1, IEC1010-1.

### PHYSICAL CHARACTERISTICS

| Dimensions | mm   | in.   |
|------------|------|-------|
| Height     | 44   | 1.734 |
| Width      | 483  | 19    |
| Depth      | 561  | 22.1  |
| Weight     | kg   | lb.   |
| Net        | 6.14 | 13.5  |
| Shipping   | 10.4 | 22.9  |

## SPG 422 Ordering Information

### SPG 422

Component Digital Sync Generator.

**Opt. 01** – Adds four independently timeable analog blackburst outputs.

**Opt. 02** – Adds a component digital test signal generator.

### Optional Accessories

**040-1639-00** Kit to add character ID to SPG422 with SN below B030000.

**040-1491-00** – Kit to add Opt. 01.

**040-1492-00** – Kit to add Opt. 02.

### Measurement Service Options

**Opt. C3** – Three years of Calibration Services.

**Opt. C5** – Five years of Calibration Services.

**Opt. R3** – Repair warranty extended to cover three years.

**Opt. R5** – Repair warranty extended to cover five years.

### For further information, contact Tektronix:

**Worldwide Web:** for the most up-to-date product information visit our web site at: [www.tektronix.com](http://www.tektronix.com)

ASEAN Countries (65) 356-3900; Australia & New Zealand 61 (2) 9888-0100; Austria, Central Eastern Europe, Greece, Turkey, Malta, & Cyprus +43 2236 8092 0; Belgium +32 (2) 715 89 70; Brazil and South America 55 (11) 3741-8360; Canada 1 (800) 661-5625; Denmark +45 (44) 850 700; Finland +358 (9) 4783 400; France & North Africa +33 1 69 86 81 81; Germany + 49 (221) 94 77 400; Hong Kong (852) 2585-6688; India (91) 80-2275577; Italy +39 (2) 25086 501; Japan (Sony/Tektronix Corporation) 81 (3) 3448-3111; Mexico, Central America, & Caribbean 52 (5) 666-6333; The Netherlands +31 23 56 95555; Norway +47 22 07 07 00; People's Republic of China 86 (10) 6235 1230; Republic of Korea 82 (2) 528-5299; South Africa (27 11)651-5222; Spain & Portugal +34 91 372 6000; Sweden +46 8 477 65 00; Switzerland +41 (41) 729 36 40; Taiwan 886 (2) 2722-9622; United Kingdom & Eire +44 (0)1628 403300; USA 1 (800) 426-2200.

From other areas, contact: Tektronix, Inc. Export Sales, P.O. Box 500, M/S 50-255, Beaverton, Oregon 97077-0001, USA 1 (503) 627-6877.

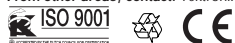

Copyright © 1999, Tektronix, Inc. All rights reserved. Tektronix products are covered by U.S. and foreign patents, issued and pending. Information in this publication supersedes that in all previously published material. Specification and price change privileges reserved. TEKTRONIX and TEK are registered trademarks of Tektronix, Inc. All other trade names referenced are the service marks, trademarks or registered trademarks of their respective companies.